

Introduction

When maximum performance is demanded from communications systems, test equipment, or any other frequency sensitive systems it is imperative to get the point where the filter response is -3dB (the breakpoint of the low pass filter placed exactly right. Placing the breakpoint correctly insures minimum distortion in the pass band, while yielding maximum attenuation of unwanted frequencies in the stop band. This is very hard to do in multiple frequency systems because when the break frequency is placed correctly for one task, it is usually by definition, wrong for another task. The described low pass filter has a breakpoint which is continuously variable over a range of 20 to 1 by varying the DC control voltage. The gain stays constant regardless of the breakpoint setting. If digital control is advantageous, a DAC can easily be interfaced into the control voltage port because the control voltage ranges from 0V to 1.5V.

The HA-2841 op amp is the main amplification element in the circuit, and it was chosen because it has excellent DC characteristics coupled with high frequency response. The input signal is amplified by the op amp, but only the DC portion of the output signal is fed directly back to the op amp summing junction. This fixes the DC gain at $-R_F/R_G$. The AC portion of the output signal is passed through the HA-2546 high frequency multiplier before it is fed back to the summing junction. The HA-2546 was chosen for this application because its extremely small time delay does not introduce distortion. The feedback capacitor, C, blocks any DC

multiplier errors. As V_X changes, the multiplier gain changes so the apparent value of C changes forcing the breakpoint frequency to change. The equation for the multiplier is given below where V_{OUTM} is the multiplier output voltage.

$$V_{OUTM} = \left(\frac{V_X V_Y}{2}\right) = \left(\frac{V_X V_{OUT}}{2}\right) \tag{EQ. 1}$$

The equations for the complete circuit response are given below.

$$\frac{-V_{OUT}}{V_{IN}} = \left(\frac{R_F}{R_G}\right) \left(\frac{1}{(1 + (V_X R_F C s / 2))}\right) \tag{EQ. 2}$$

$$\omega = 2\pi f = \frac{1}{V_X R_F C} \tag{EQ. 3}$$

The control voltage, V_X , in conjunction with R_F and C determine the breakpoint frequency, ω . R_F and C are used to center the frequency range, and V_X varies the frequency within this range. Both R_F and R_G set the gain, so there is plenty of flexibility in the component selection. The component values shown in the figure yield a frequency range from 1.7MHz when $V_X = 0.1V$ to 80kHz when $V_X = 1.25V$. The control input is similar to an op amp input, thus it need not be driven by a low impedance source. This input may be driven from a DAC to obtain digital control of the breakpoint, but the DAC output voltage must be level shifted to 0V to 1.5V.

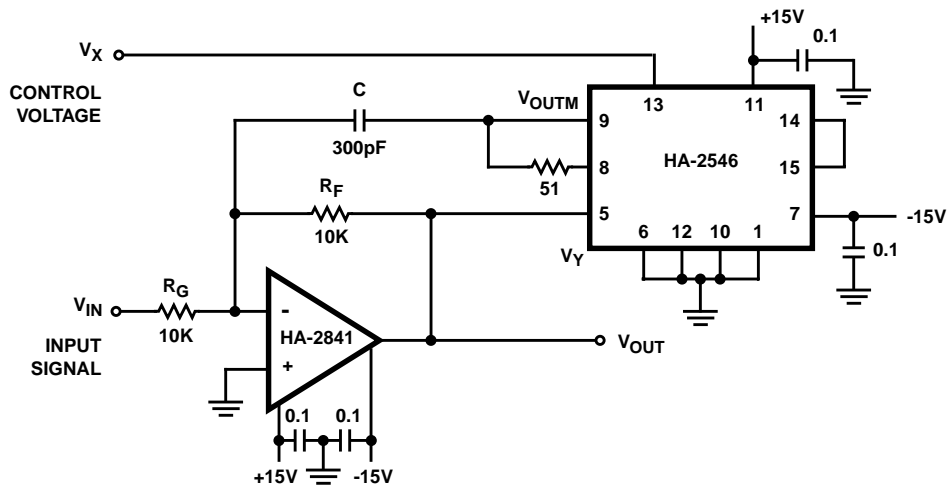

FIGURE 1. DC VOLTAGE CONTROLLED LOW PASS FILTER

All Intersil semiconductor products are manufactured, assembled and tested under **ISO9000** quality systems certification.

Intersil semiconductor products are sold by description only. Intersil Corporation reserves the right to make changes in circuit design and/or specifications at any time without notice. Accordingly, the reader is cautioned to verify that data sheets are current before placing orders. Information furnished by Intersil is believed to be accurate and reliable. However, no responsibility is assumed by Intersil or its subsidiaries for its use; nor for any infringements of patents or other rights of third parties which may result from its use. No license is granted by implication or otherwise under any patent or patent rights of Intersil or its subsidiaries.

For information regarding Intersil Corporation and its products, see web site www.intersil.com

Sales Office Headquarters

NORTH AMERICA

Intersil Corporation
P. O. Box 883, Mail Stop 53-204
Melbourne, FL 32902
TEL: (321) 724-7000
FAX: (321) 724-7240

EUROPE

Intersil SA
Mercure Center
100, Rue de la Fusee
1130 Brussels, Belgium
TEL: (32) 2.724.2111
FAX: (32) 2.724.22.05

ASIA

Intersil (Taiwan) Ltd.
7F-6, No. 101 Fu Hsing North Road
Taipei, Taiwan
Republic of China
TEL: (886) 2 2716 9310
FAX: (886) 2 2715 3029